

2015518

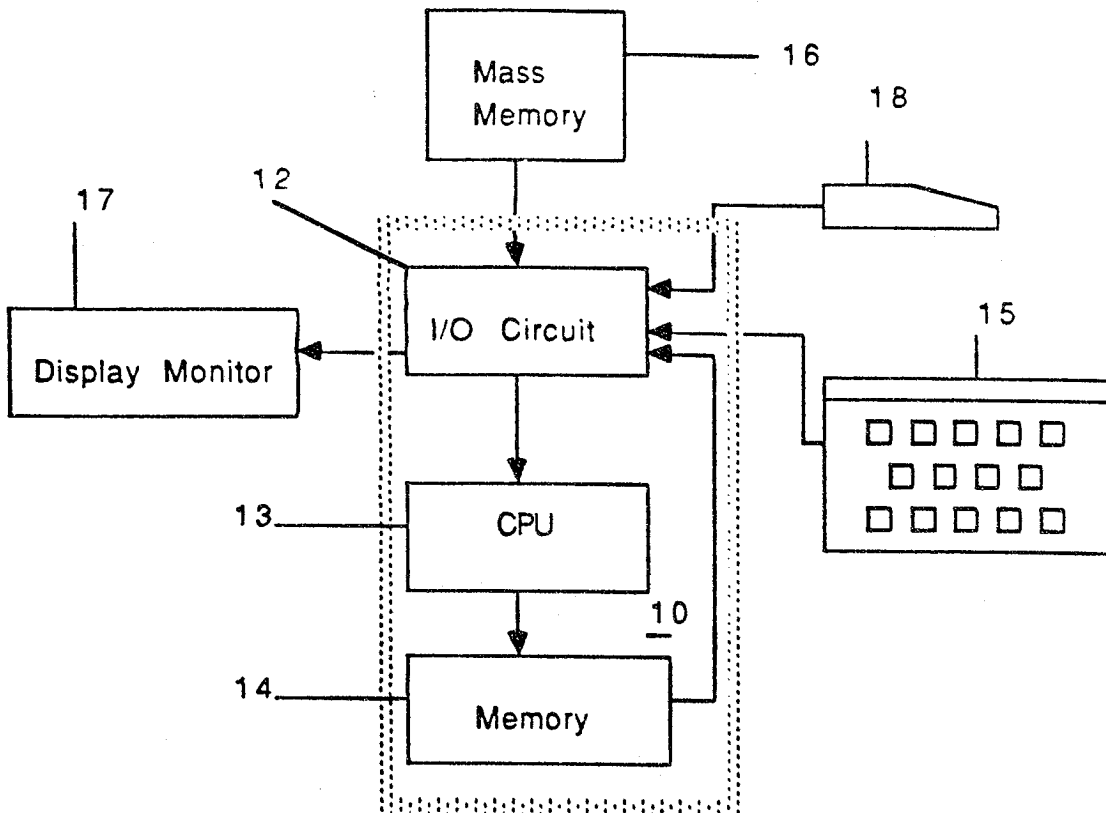

Fig 1

Richard Mc Kenzie & Herbert

2015518

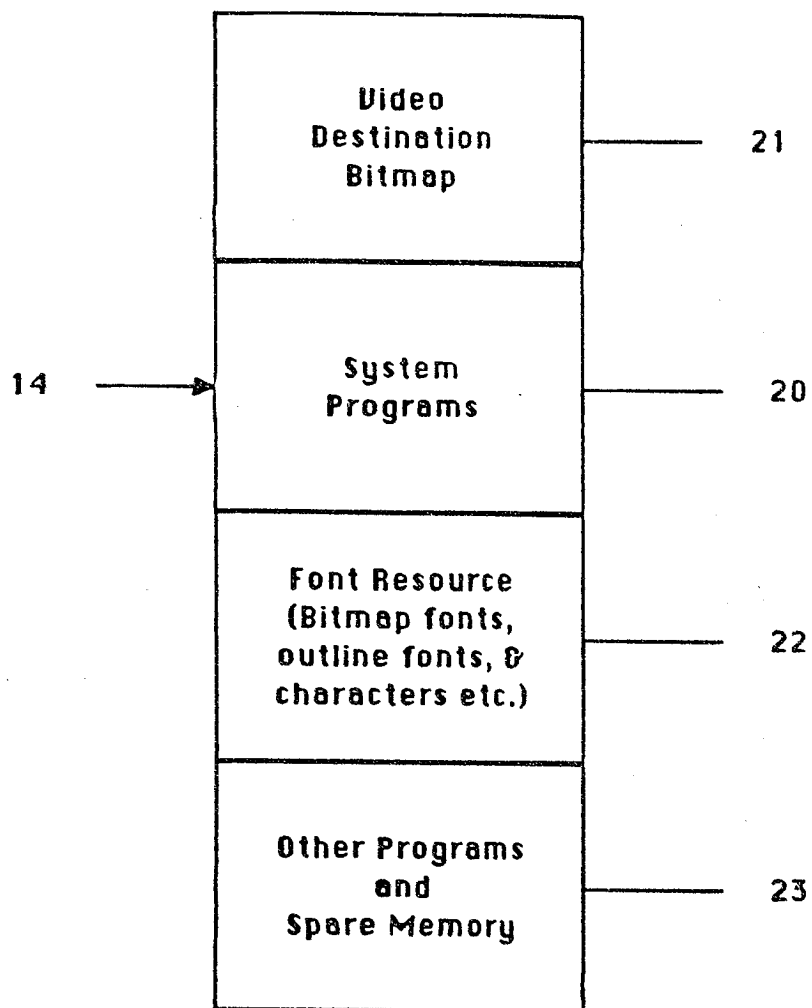

Fig 2

Richard Mc Kenzie & Herbert

2015518

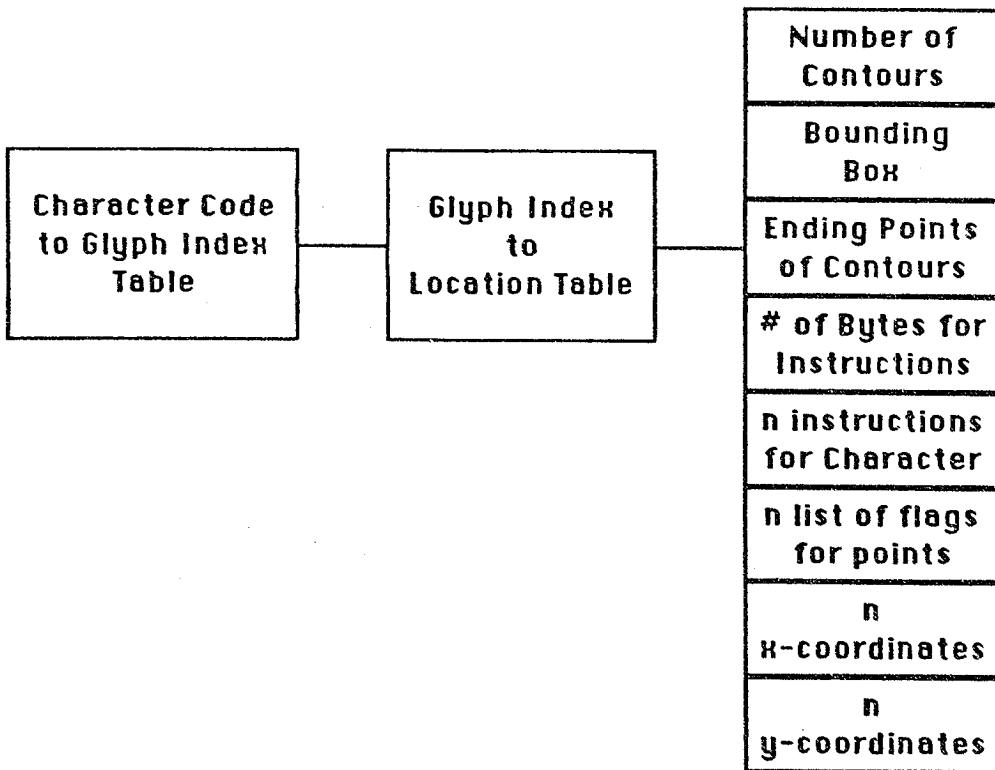

Fig 3

Richard Mc Kenzie & Herbert

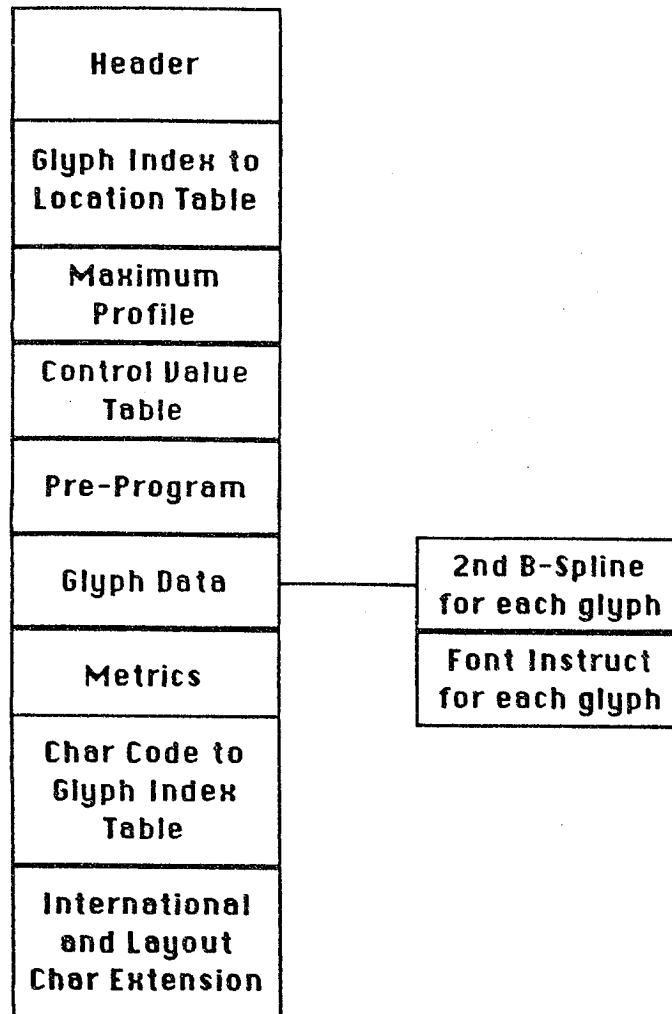

Fig 4

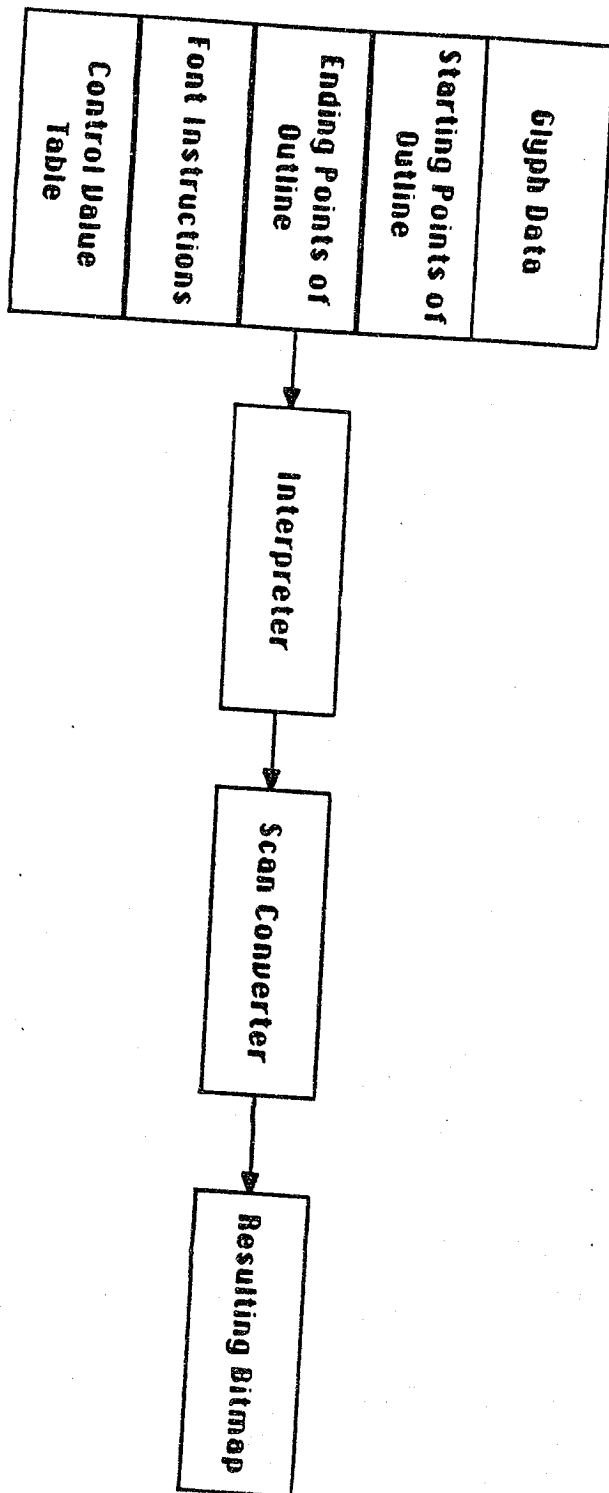

Fig 5

Lichen Mc Kenzie & Herbert

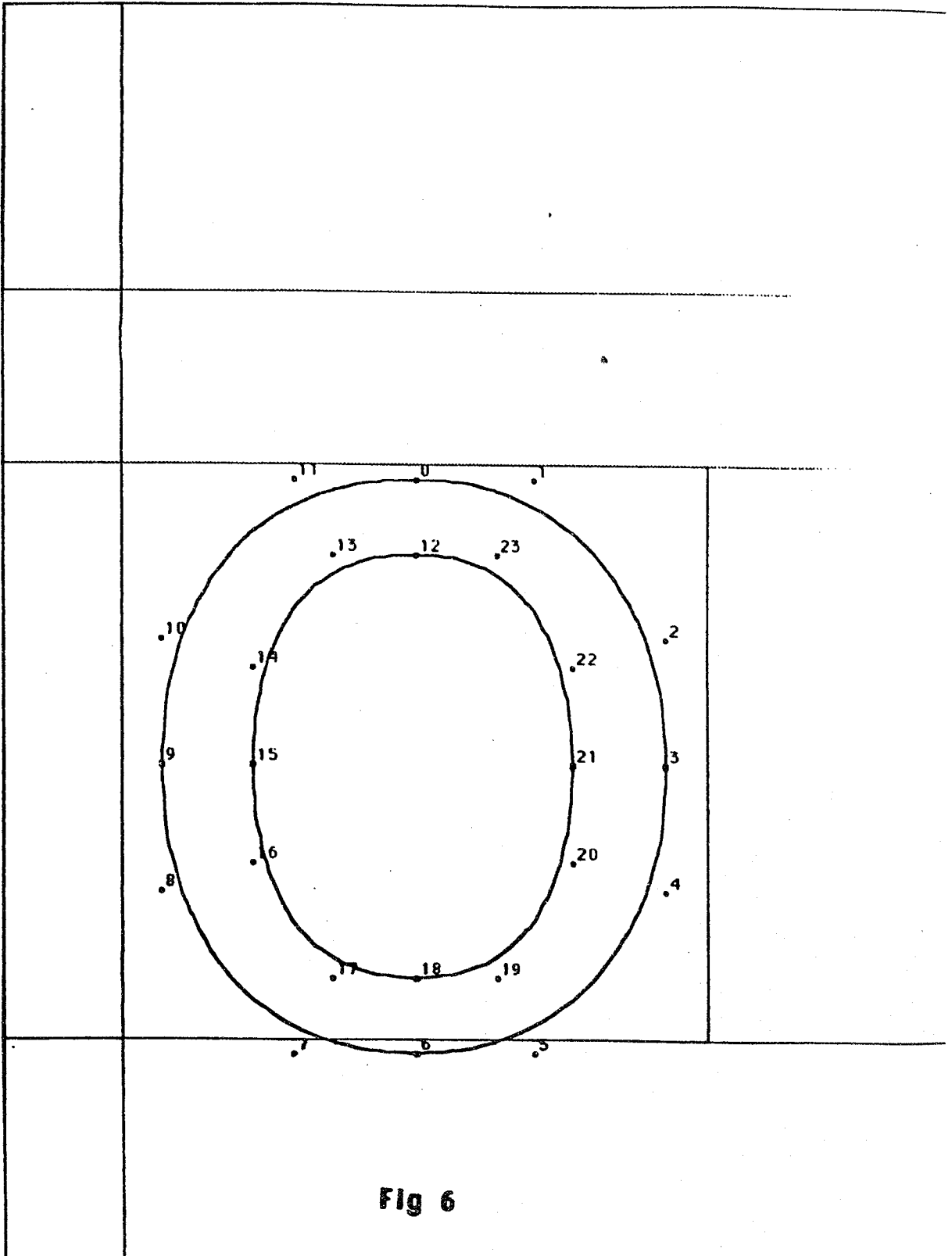

Fig 6

Richard M. Kozie & Hubert

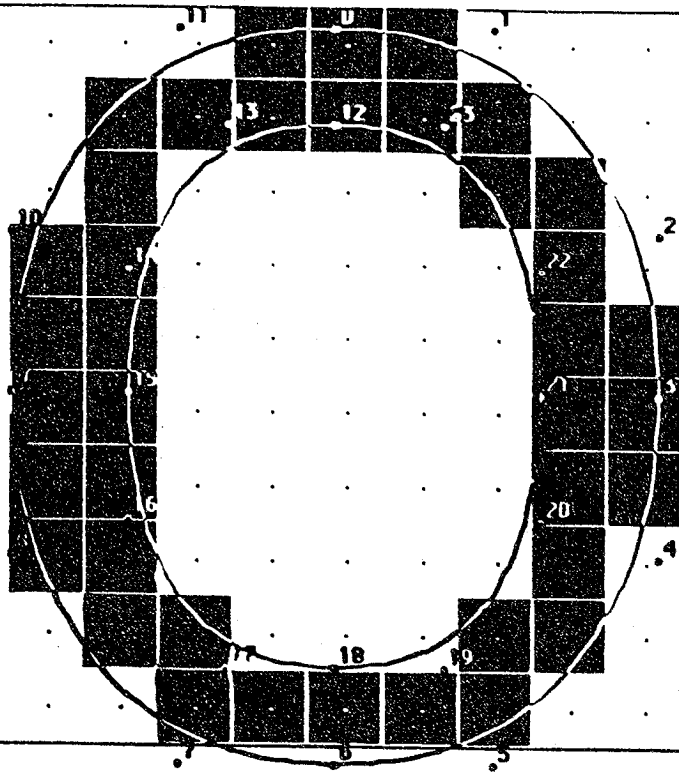

Fig 7

Richard Mc Kenzie & Herbert

```

NPUSHE ]
MDAP[1] 9
MIRP[01101] 15 37
MDRP[11101] 3
MIRP[01101] 21 37
IUP[1]
DELTA[0] 86 1 86 5 214 11 217 1 214 7 217 5 230 11 233
          1 230 7 233 5 242 11 253 1 242 7 253 5

SVTCA[0]
MIAP[0] 0 6
MIRP[01101] 12 24
MIAP[0] 6 3
MIRP[01101] 18 24
IUP[0]
DELTA[0] 51 11 60 7 60 5 51 1 67 11 76 7 76 5 67 1 166
          4 169 10 166 8
    
```

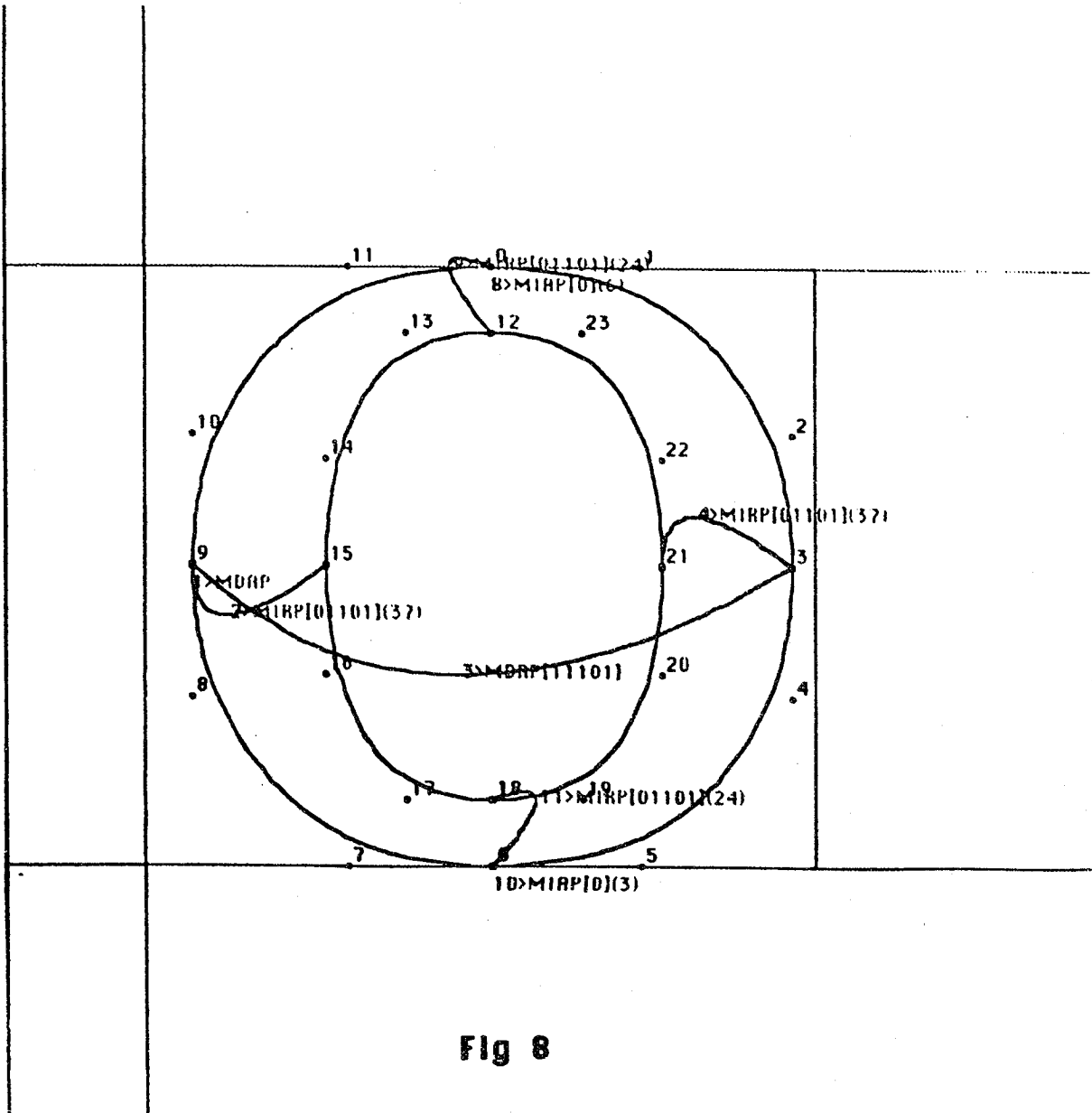

Fig 8

Liesha Mc Kenzie & Herbert

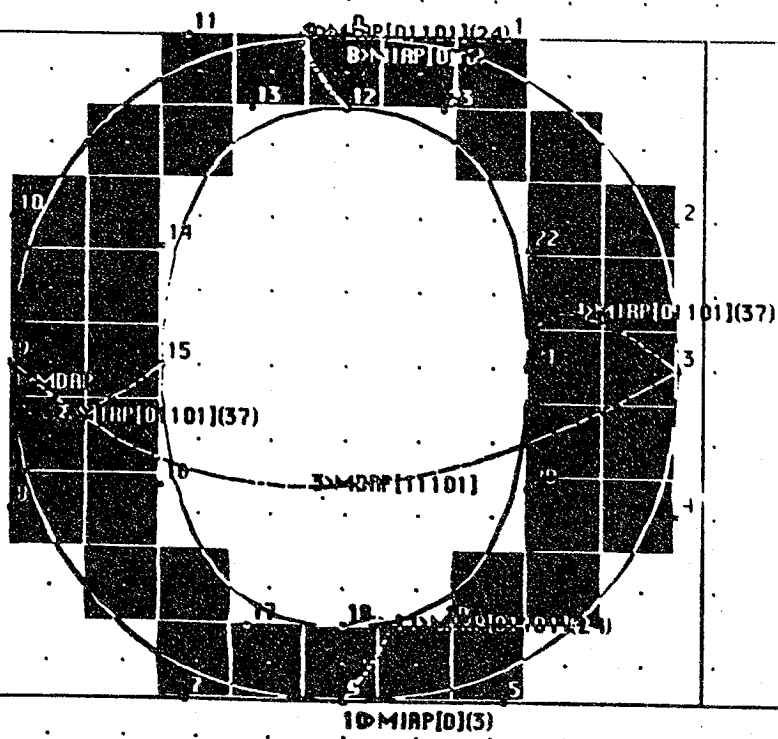

Fig 9

Lieser Mc Kozie & Herbert

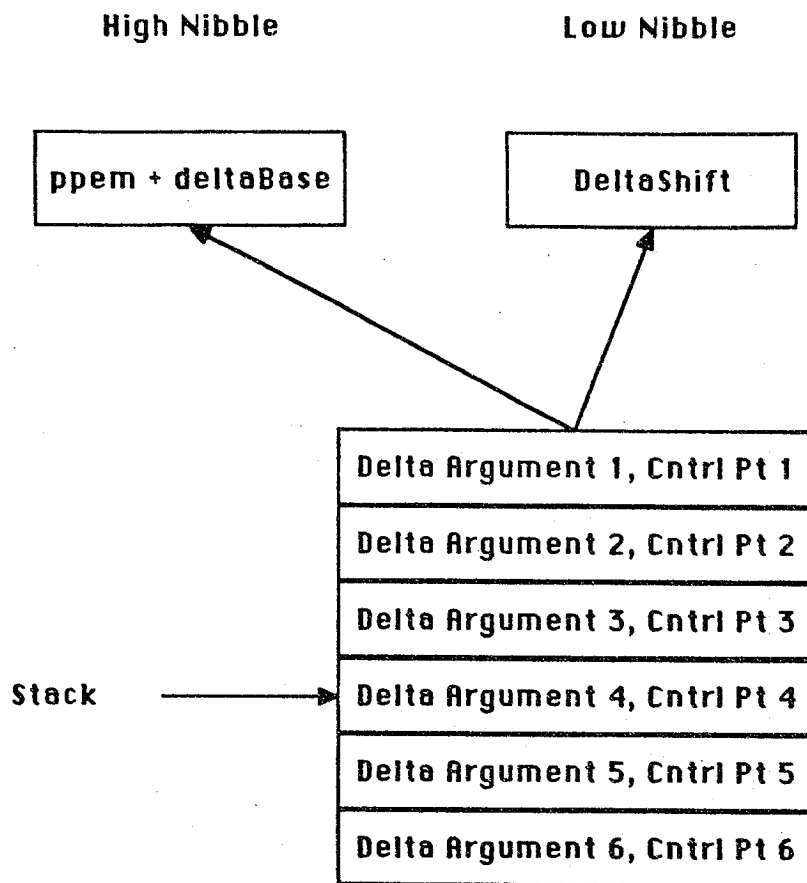

Fig 10

Input Range	Output Range
0	-8
1	-7
2	-6
3	-5
4	-4
5	-3
6	-2
7	-1
8	1
9	2
10	3
11	4
12	5
13	6
14	7
15	8

Fig 11

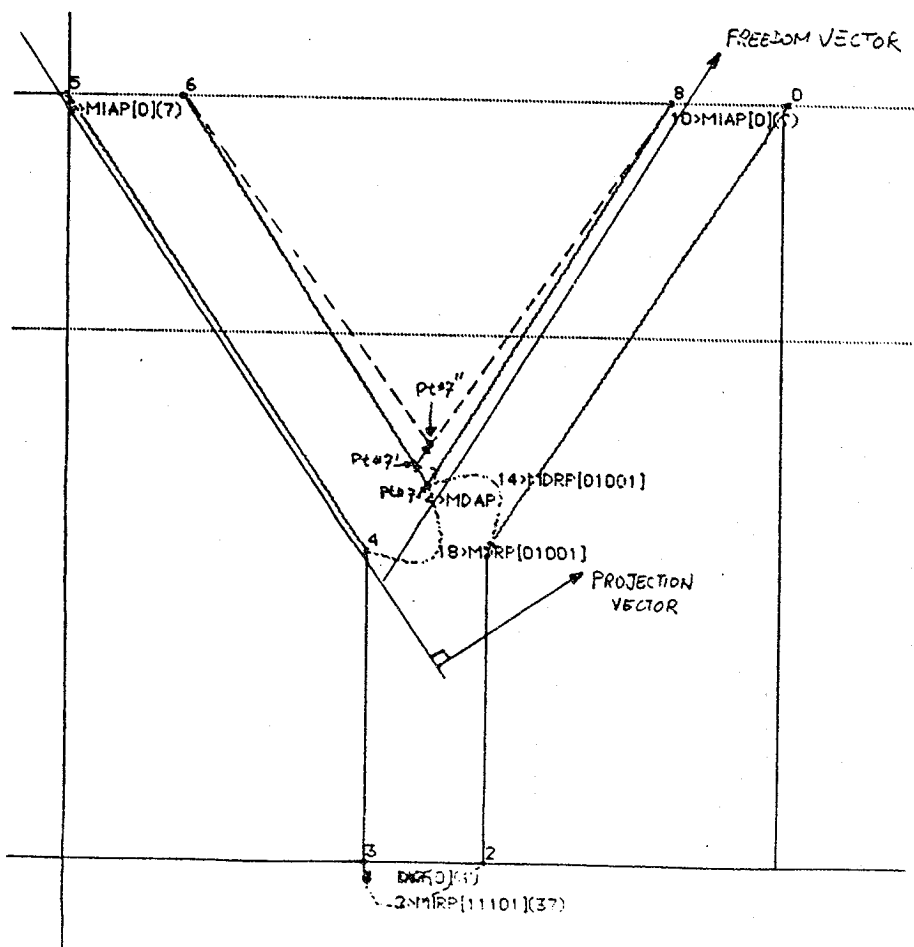
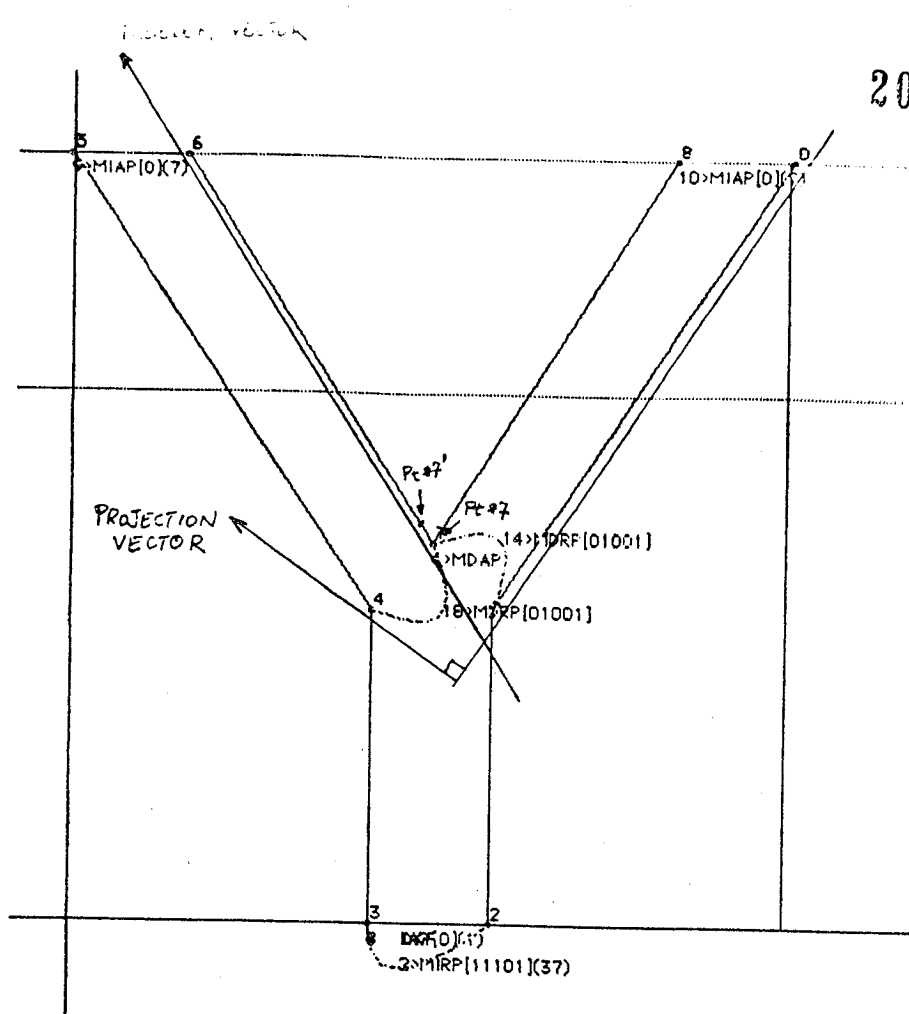

Fig 12

Richard Mc Kenzie & Herbert

H 1.0A163•Instructions

Pts:[1,1,7] R2G:1 Loop:0
 minD:64 sWide:0 FLIP ΔB:9 ΔS:3

Proj:  Free: 

Stack: 7 8 4 7 10 ...

```

0>NPUSHB[0]
1>MDAP[1] 3
2>MIAP[11101] 2 37
3>IP[0] 7
4>MDAP[1] 7
5>IUP[1]
6>DELTA[0] 24 5 76 8 68 6 92 8 8
7>SUTCA[0]
8>MIAP[0] 3 1
9>MIAP[0] 5 7
10>MIAP[0] 8 7
11>SPUTL[1] 0 1
12>SFUTL[0] 6 7
13>SRPO[0] 1
14>MDAP[01001] 7
15>SPUTL[1] 5 4
16>SFUTL[0] 8 7
17>SRPO[0] 4
18>MDAP[01001] 7
19>IUP[0]
20>SUTCA[0]
21>DELTA[0] 56 4 56 1 73 1 73 4 9

```

Fig 13

Lisha Mc Koyie & Herbert